



Features

- 100% oil free
- 100% duty cycle
- Compact and easy to use
- Easy maintenance
- Long-life, 2-year warranty
- 8000 hours cup life at 8bar
- 4000 hours maintenance interval for the dryer

Description

- Built-in 2-column adsorption dryer
- Pressure dew point down to -40°C
- 1µm air filtration (class 2 for dust according to ISO8573.1:2010)
- Pressure regulator included
- Receiver with internal coating and 5-year warranty

OTHER VERSIONS

- Without dryer (2xOF302-40B)
- With soundproofing cabinet (2xOF302-40MQ2)

Product Specifications

Model		2xOF302-40BQ2		
Voltage	V	1x230	1x230	1x120
Frequency	Hz	50	60	60
Motor	HP	1.2	1.2	1.2
	kW	0.9	0.9	0.9
Displacement	l/min	216	276	276
Air flow @ 8bar	l/min	60	70	70
	cfm	2.12	2.5	2.5
Max. pressure	bar	8	8	8
	psi	120	120	120
Max. current	A	7.6	8.2	13.2
	Receiver volume	litres	40	40
Weight	kg	59	59	59
	lbs	130	130	130
Noise level	dB(A)/1m	68	68	68
Duty cycle		100%	100%	100%

Air flow / pressure curve ¹⁾

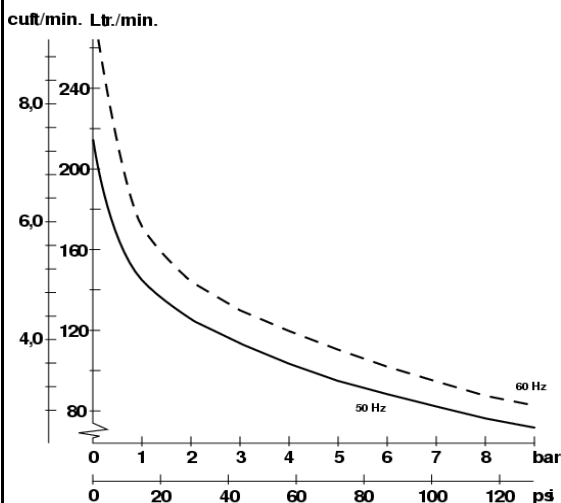

Dimensions - inches / [mm] ²⁾

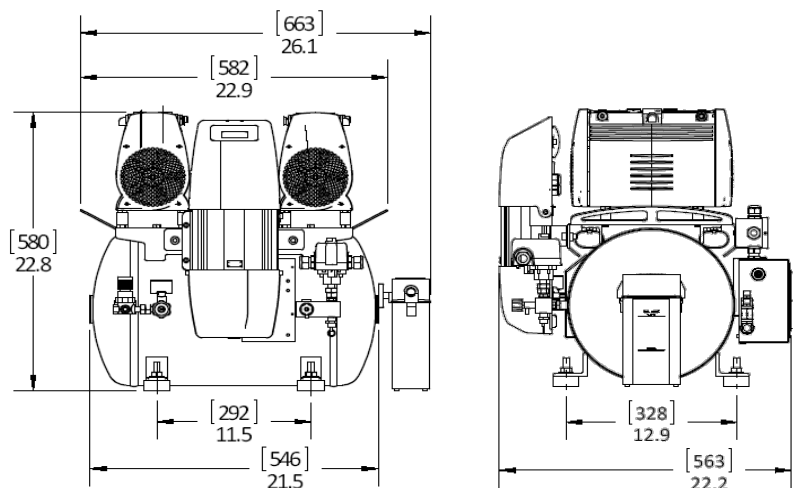

1) air flow is reduced by 18 to 20% on units with dryers

2) for unit without accessories or options