



Features

- Extremely quiet
- Excellent reliability
- Compact and easy to use
- Easy maintenance
- Long-life, 2-year warranty
- 50% duty cycle

Description

- 5µm air filtration
- Pressure regulator included
- 5-year warranty on receiver

Accessories

- 0.01µm filtration
- Receiver autodrain system
- Condensate bottle

Product Specifications

| Model | 24-40 | | |
|-----------------|----------|-------|-------|
| Voltage | V | 1x230 | 1x230 |
| Frequency | Hz | 50 | 60 |
| Motor | HP | 1.84 | 1.84 |
| | kW | 1.35 | 1.35 |
| Displacement | l/min | 200 | 240 |
| Air flow @8bar | l/min | 128 | 148 |
| | cfm | 4.52 | 5.23 |
| Max.pressure | bar | 8 | 8 |
| | psi | 120 | 120 |
| Max.current | A | 11.6 | 11.6 |
| Receiver volume | litres | 40 | 40 |
| | gallon | 10.6 | 10.6 |
| Weight | kg | 84 | 84 |
| | lbs | 185 | 185 |
| Noise level | dB(A)/1m | 56 | 56 |
| Duty cycle | | 50% | 50% |

Air flow/pressure curve

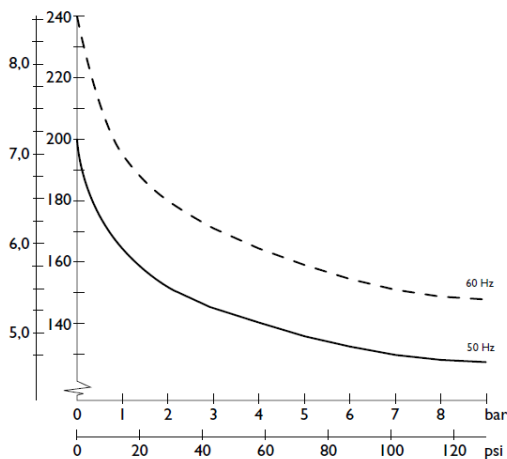

Dimensions - mm / [inches] *

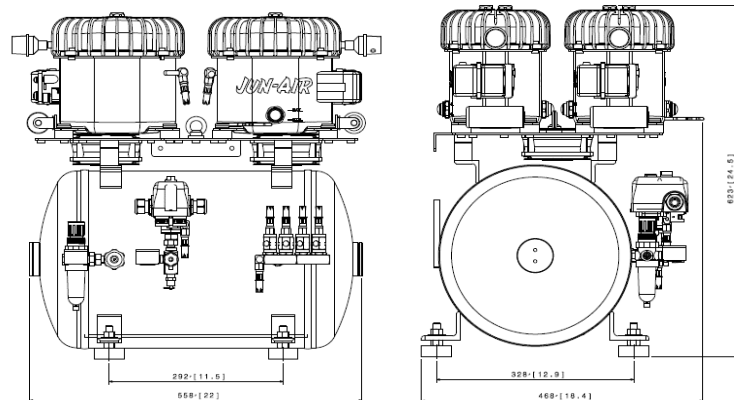

* for unit without accessories