



### Features

- Extremely quiet
- Excellent reliability
- Compact and easy to use
- Easy maintenance
- Long-life, 2-year warranty
- 50% duty cycle

### Description

- 5µm air filtration
- Pressure regulator included
- 5-year warranty on receiver

### Accessories

- 0.01µm filtration
- Receiver autodrain system
- Condensate bottle

## Product Specifications

Model	18-40		
Voltage	V	1x230	1x230
Frequency	Hz	50	60
Motor	HP	1.38	1.38
	kW	1.01	1.01
Displacement	l/min	150	180
Air flow @ 8bar	l/min	96	111
	cfm	3.39	3.92
Max. pressure	bar	8	8
	psi	120	120
Max. current	A	8.7	8.7
Receiver volume	litres	40	40
	gallon	10.6	10.6
Weight	kg	62	62
	lbs	137	137
Noise level	dB(A)/1m	50	50
Duty cycle		50%	50%

## Air flow / pressure curve

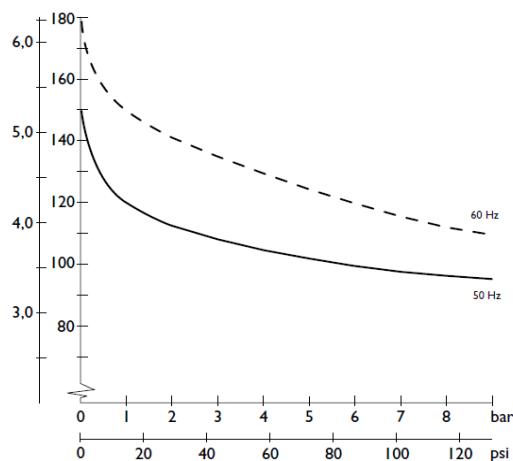

## Dimensions - mm / [inches] \*

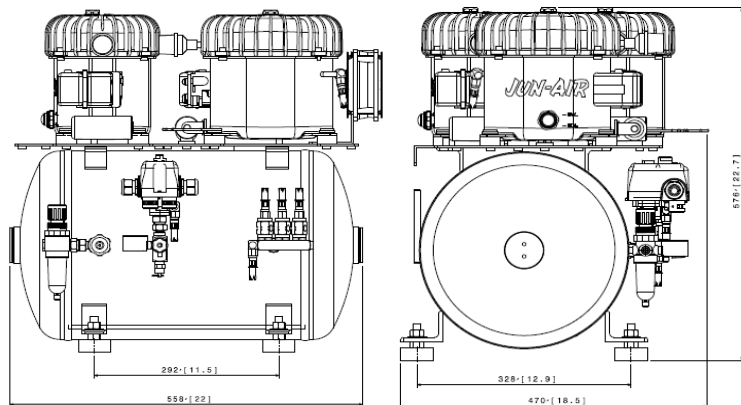

\* for unit without accessories